

HANDBOOK FOR ROLLING DOORS

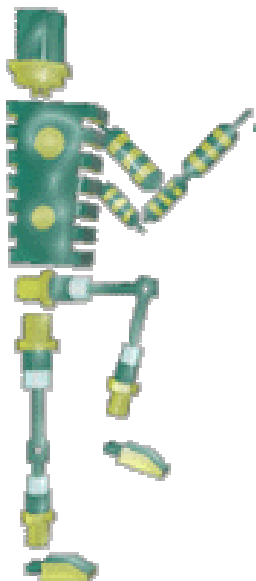

**HIGHT QUALITY
GOOD PRICE
EASY ASSEMBLY**



CONTROL Y ACCESOS, S.L.

AUTOMATISMOS ELECTRÓNICOS

C/ Xavier Puig i Andreu, 42 bajos 25005 LLEIDA

Tel. 973 24 88 42 Fax 973 22 06 21

e-mail : cya@controlyaccesos.es

www.controlyaccesos.com

BASIC INFORMATION

The operating voltage of the device is 230 VAC single phase 50Hz with a nominal consumption of 1.75 A.

It is therefore necessary that the supply line of equipment is a single line of section minimum 2.5 mm² and capable of supporting peak consumption of 10 A.

It is not necessary a specific maintenance for this equipment, although they are recommended periodical inspections to prevent small damages arising from the usage, which can generate bigger problems.

The equipment transportation must be realized respecting the indications of position, showed in the containing box, and it is suggested to storage it in a dry place avoiding temperatures below -5°C, or above 50°C.

SECURITY SYSTEMS AND USE CONDITIONS

The protection of the device against the input of 230VAC is given by a breaker of 10A, which is activated when the consumption balance is higher than the assigned.

As a security usage system the equipment has in itself a team of photocell sensor barrier that in the case of interruption of the beam of light, the system prevents the closing of the door or inverts the movement if it is being executed.

Its usage have not any associated dangers, but it is highly recommended a rational use of it, without any other use rather than the specified one, trying to distance it form any other type of operation.

ROLLING DOORS DETAILS

CANVAS' DETAILS

The canvas's grammage is 900 and with a thickness of 0.8mm

A rupture's resistance of 3500N/5cm according to BS 3424 method 6 A

A tear resistance of 600 N

The working temperature is -30 °C (for freezing door) / + 70 °C

Possibility of supplying it in different colours

The formula to calculate the degree of thermal insulation is the following:

$$K1= 67 \text{ W m}^2 \text{ K}$$

CANVAS COLOURS

Colour	RAL
Yellow	1003
Orange	2004
Red	3002
Blue	5010
Green	6028
Gray	7038
White	9016

TRANSPARENT PVC CHARACTERISTICS

The transparent PVC density is 1.22 g/cm³ and it has a thickness of 3 mm

A rupture's resistance of 1.6 daN/mm² according to ASTM D638.

A tear resistance of >50 daN/cm³

The working temperature is +50 °C

Global transparence is 80 %

ALUMINUM AND PROFILES DETAILS

The profiles are of extruded aluminium and of self design.

The composition characteristics are governed according to UNE-EN 573-3 Dimensional tolerances as UNE- EN 775-9

Profiles are extruded with an alloy of 6060 and treated with heat-T5, with a Brinell hardness of 60.

The standard colour is white RAL9010, other colours under request only.

Quick track door _____ weight 2722 g/m _____ and 2.0 mm thick.

Cover front quick door _____ weight 1299 g/m _____ and 1.7 mm thick.

Cover back quick door _____ weight 1574 g/m _____ and 1.7 mm thick.

Quick Track door special _____ weight 5092 g/m _____ and 3.0 mm thick.

Cover front quick

door special _____ weight 3196 g/m _____ and 3.0 mm thick.

Cover back quick

door special _____ weight 4282 g/m _____ and 3.0 mm thick.

Tambour-weight aluminium_ weight 4366 g/m _____ and 2.7 mm thick.

Freezing track door _____ weight 3954 g/m _____ and 2.0 mm thick.

WEIGHT OF THE DOOR IN FUNCTION OF HIS DIMENSIONS

FAST DOOR		
HIGH [cm]	WIDE [cm]	WEIGHT [Kg]
200	200	65
250	200	70
250	250	75
300	250	80
300	300	85
350	300	90
350	350	95

SPECIAL FAST DOOR		
HIGH [cm]	WIDE [cm]	WEIGHT [Kg]
200	200	90
300	300	120
400	400	150
400	450	160
500	450	170
500	500	190
600	600	220

CONTROL SYSTEM CHARACTERISTICS

The system control consists on:

A detection position system by magnetic encoder, by which you will get a set of null system maintenance, and a transfer continuous of data.

A robot of control directly designed for the implementation of closures which their data analysis system links with the ability to customize the performance characteristics of it by the customer.

Electronic frequency control which controls the engine and achieves a smooth movement of the door, preserving the durability and different mechanical part of the system.

LIST OF DOOR COMPONENTS

QUICK DOOR PIECES

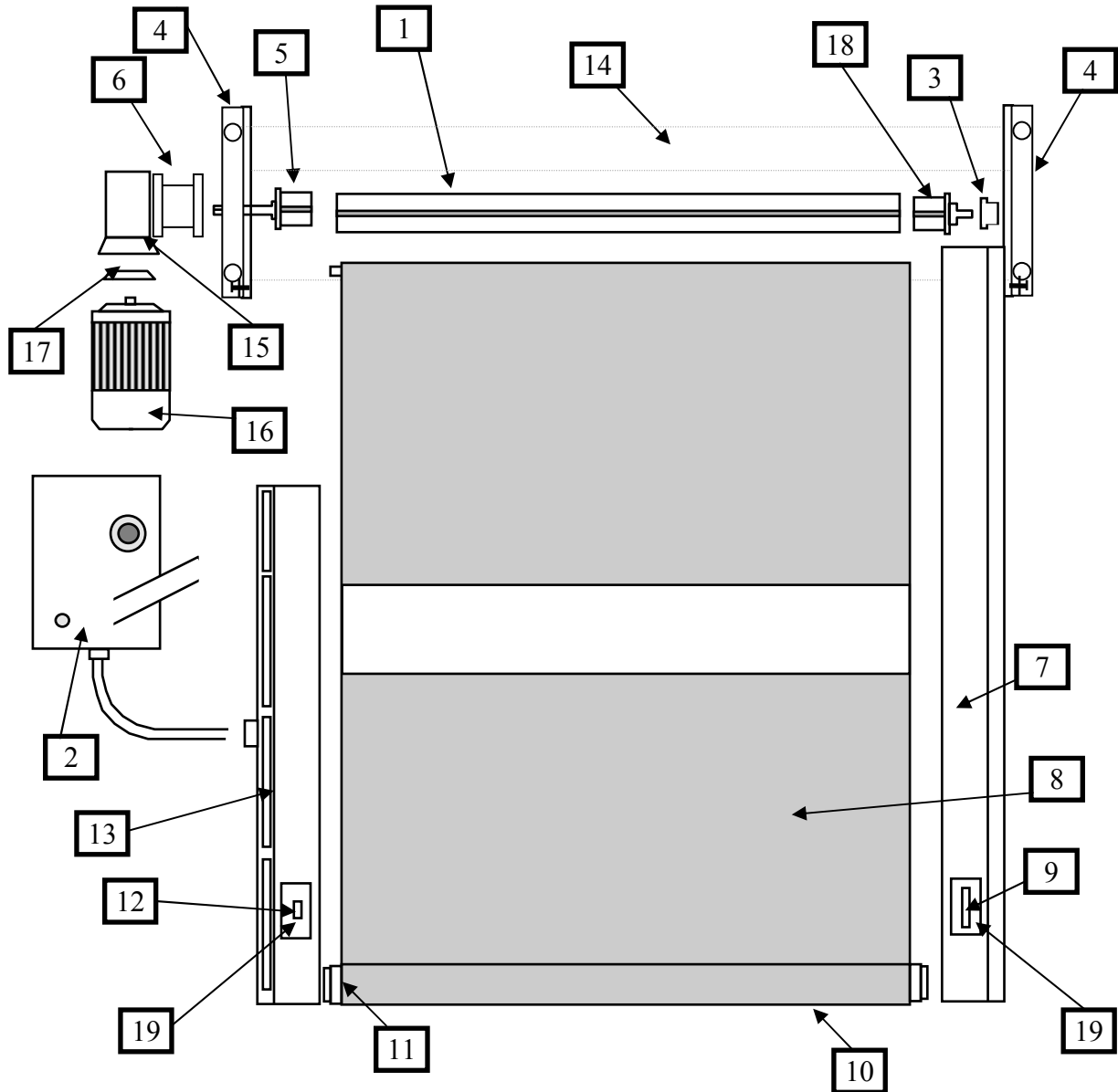

- 1 .- Tambour roll canvas
- 2 .- Electronic control (card)
- 3 .- Nylon bushing
- 4 .- Ear-muffs Support
- 5 .- long axis with sleeve
- 6 .- Bearing box (Separator support)
- 7 .- Aluminium track
- 8 .- PVC Canvas
- 9 .- photocell emitter

- 10.- Aluminium counter balance
- 11.- Sliding chair
- 12.- Photocell with holder
- 13 .- Safety Reeds
- 14 .- Shaft cover
- 15 .- Reducer
- 16.- Motor
- 17.- Encoder
- 18 .- Short Axis with sleeve
- 19 .- Photocell Support

ASSEMBLY INSTRUCTIONS QUICK INSTALLATION OF FAST ROLLING DOORS

1- Spread out the guides as shown in the following drawing and raise it.



2- Fit the guiders with the ear-muffs on both sides of the door using M 10 screws with their eye nuts.

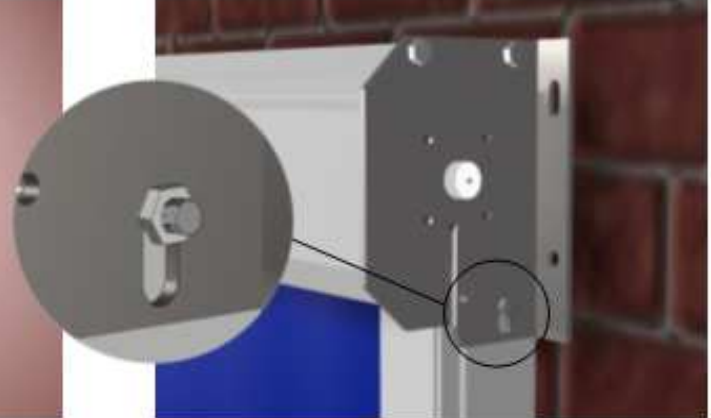

3. - Level the door. Then, drill the panel and set the Plug (chino) to fix it, firmly to both sides.

4. - Fix the door on the floor by placing an M8 plug, a washer and a screw on both sides.

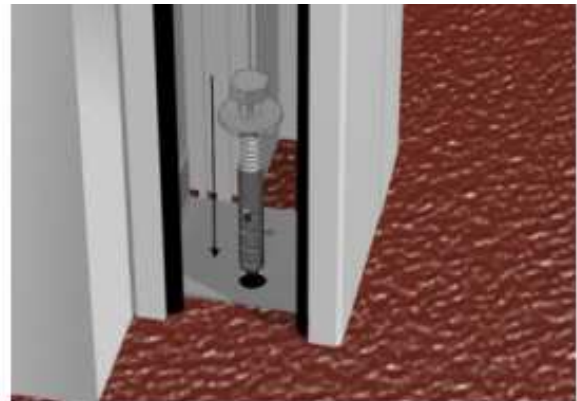

5.-Open the box and set in 4 plugs with their screws to fasten it to the wall.

6-Drill a \varnothing 10.5 hole horizontally and vertically centred, passing through the wall from the inner side to set the fastening bolt in place.

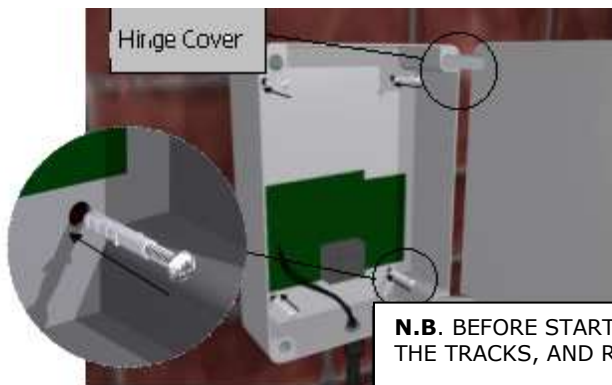

N.B. BEFORE STARTING UP, UNROLL THE CANVAS MANUALLY, CENTRE IT WITH THE TRACKS, AND ROLL IT UP AGAIN.

GUIDE GENERAL ASSEMBLY

✓ Assembly the Tambour at level.

✓ Align the guides so that at the bottom part of the door, the distance between guides must be 1cm more than the top of it (0.5 cm for each side).

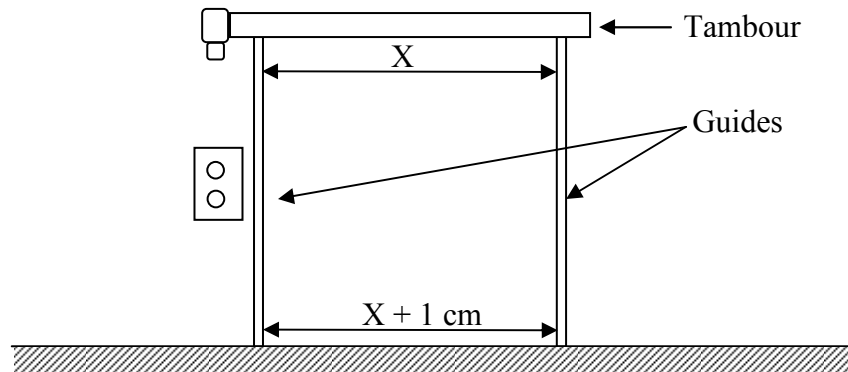

✓ Hold guides to the wall with the nylon rod.

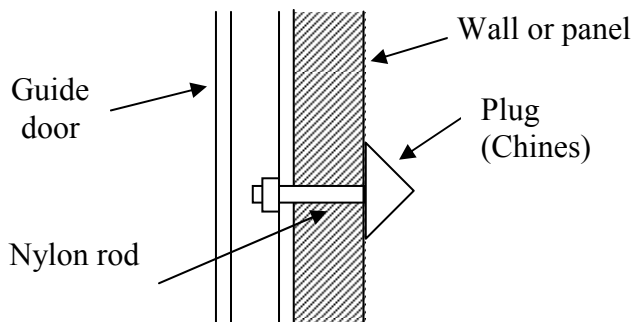

✓ Place a fixing screw from the guides to the ground.

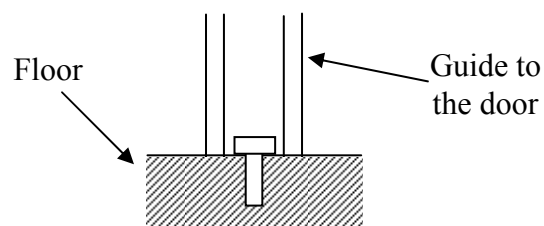

- ✓ Fill any gaps left between the track and the wall with silicone
- ✓ Check that the canvas is fit in 6cm in each side of the guider.
- ✓ Align properly the security photocell.
- ✓ Connect the tubes by the bottom part of the control table.
- ✓ Cut the left tube over the control panel.
- ✓ Stretch completely the antenna of the control board to place it in a vertical position.

Taking care of the last details

DIAGRAM OF THE ELECTRONIC CONTROL

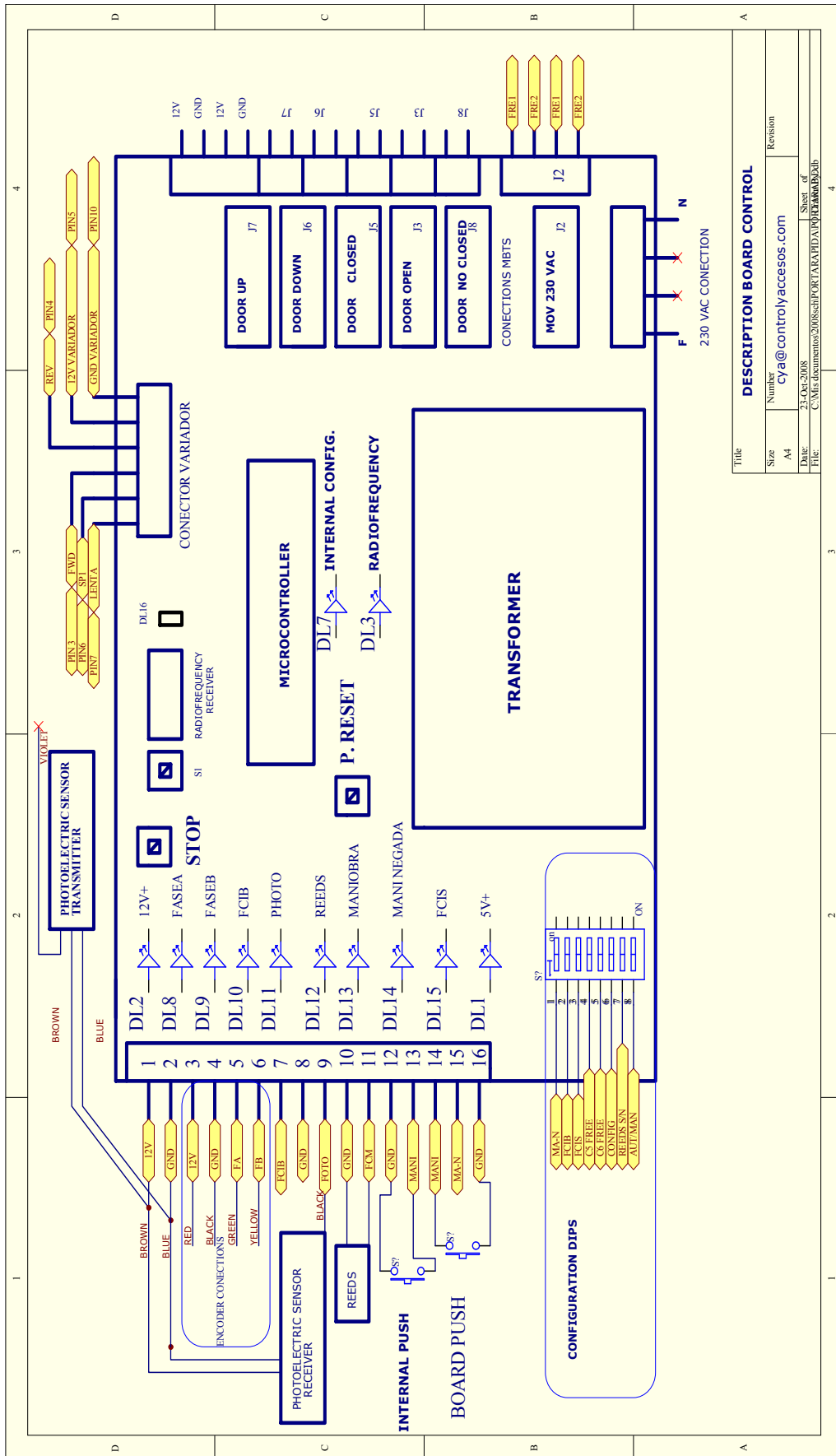

Title	
DESCRIPTION BOARD CONTROL	Revision
Size: A4	Number: Cya@controlyaccos.com
Date: 23-Oct-2008	Sheet of
File: C:\Mts\documentos\2008\sch\PORT\AREA\PIDA\PORT\AREA\B01b	

230VAC CONNECTION

We only have two places for the connection of the 230 V AC to our devices. In the pneumatic and electrical automatism and fast doors the supply voltage connection is done **in the emergency stop**, and in the special fast doors the 230 V AC plug in **the terminals already indicated for that**: ground to the green/yellow terminal, neutral in the blue terminal and phase in the grey one.

Pneumatic automatism
Electric automatism
Fast door

IN THE **EMERGENCY STOP**

Special fast door

AT THE **TERMINALS CONNECTION**

PHOTOCELL ELECTRIC CONNECTION (LED of photocell DL11)

In the rolling doors (fast and special fast doors), the photocell is already prewired and we only need to join the photocell sensor wires of the track which doesn't have the engine to the wires that come from the cover which supplies power. Red with brown, black with blue and violet is not connected.

Hose's Enclosure

Red ----- Brown
Black ----- Blue

Hose photocell sensor

Violet (not connected)

In the electrical and pneumatic automatisms, photocell sensors are mirror reflection and the connections are the following:

Brown	(+)	to terminal No. 1	positive
Blue	(-)	terminal in the No. 2	negative
Gray	C	to terminal No. 8	common
Black	NA	to terminal No. 9	open contact

CONNECTING THE INNER PUSH (PUSH LED DL13)

The connection of the inner camera push happens in the terminals No. 12 and No.13, it is an open contact in which the board is connected in parallel with the electronic control push button.

SETTING THE SYSTEM

Operation ways:

Manual Operation

In this way, the door is opened and closed manually through the push button for control.

To configure the system in this way, we set the programming DIP (dual-in line package) number 8 in S2 in the state of OFF.

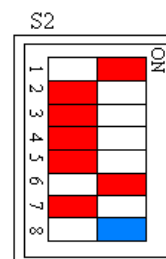

Time mechanism operation

In this way, the door will open manually, through the push button for control, and it will close automatically after a period of time.

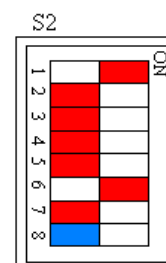

To configure the system in this way, we set the programming DIP (dual-in line package) number 8 of S2 in the state of ON.

SETTING OF THE REMAINIG OPEN TIME FOR ELECTRIC DOORS

ONLY FOR THE TIME MECHANISM **MODE**

To modify the time in which the door must remain open we have to follow these steps:

1st Push the 'RESET' button.

2nd Push the **button for control**, and then the door will start to open.

3rt Thereafter hold the Stop button pressed.

4th Once the door is totally stopped at the top, allow the opening time desired to pass holding the STOP button all the time.

5th Once the desired time has passed, press the button for control in order to close the door. Then, we realise the STOP button.

VARIATION OF THE WORKING POINT

Programming the locking point

In order to program the locking point on the door, we follow these steps:

1st We set No.6 programming DIP in S2 at OFF

2nd Press the RESET button.

3rd Press the button for control and hold. The door will rise slowly to the top of it and then will go down again. When the door is halfway up, we realise the button control to stop automatically the door.

Then, pressing the button control at intervals the door goes down following the intervals. In this way, we place the door till the locking desired point (left **a pair of centimetres** less because of the inertia of the door).

If it goes too far down, let's press the STOP button at small intervals and the door will rise following them up until the desired point.

4th Once set the point, we place the No. 6 programming DIP at ON recording the changes done.

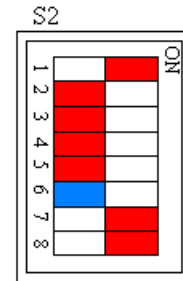

FREQUENCY VARIATOR CONNECTING ARRANGEMENT

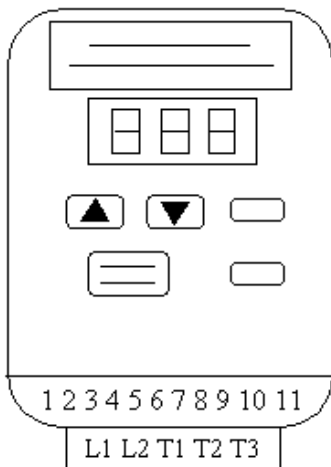

- 1 - Positive Power bulb button START
- 2 - Jumper with 5
- 3 - Red cable toward the board (FWD)
- 4 - Gray cable toward the board (REV)
- 5 - Yellow cable toward the board (+12 V)
- 6 - Blue cable toward the board (SP1)
- 7 - Green Cable toward the board (RESET)
- 8 - Without Connection
- 9 - Without Connection
- 10 -White cable towards the board and negative feeding START button (0V)
- 11 - Without Connection

L1 and L2 – input power of 230 VAC drive
T1, T2 and T3 – output engine

CONNECTING ARRANGEMENT OF THE REMOTE CONTROL RECEPTION

To configure the reception channel of the remote control (the keyboard number which will open the door), is necessary to follow these steps.

- 1) Press the button S1 from the circuit board receiver to light up the LED DL16 from the same board (Fig.1)
- 2) During some seconds, LED DL16 will remain lighted and during that time, we can record the number to open the door. (After that period of time, LED will turn off and to record the desired channel, we have to come back to step number 1)
- 3) While LED DL16 from the receiver circuit is lighted we have to press the desired number in the remote control for the opening of the door. When the light starts to blink, the receptor is configured.
- 4) Upon completion of the above steps, places us before the camera and pressing on the command, the number previously recorded, if the door opens, it means that the recording had been correct, in the opposite case, we ought to repeat the complete process.

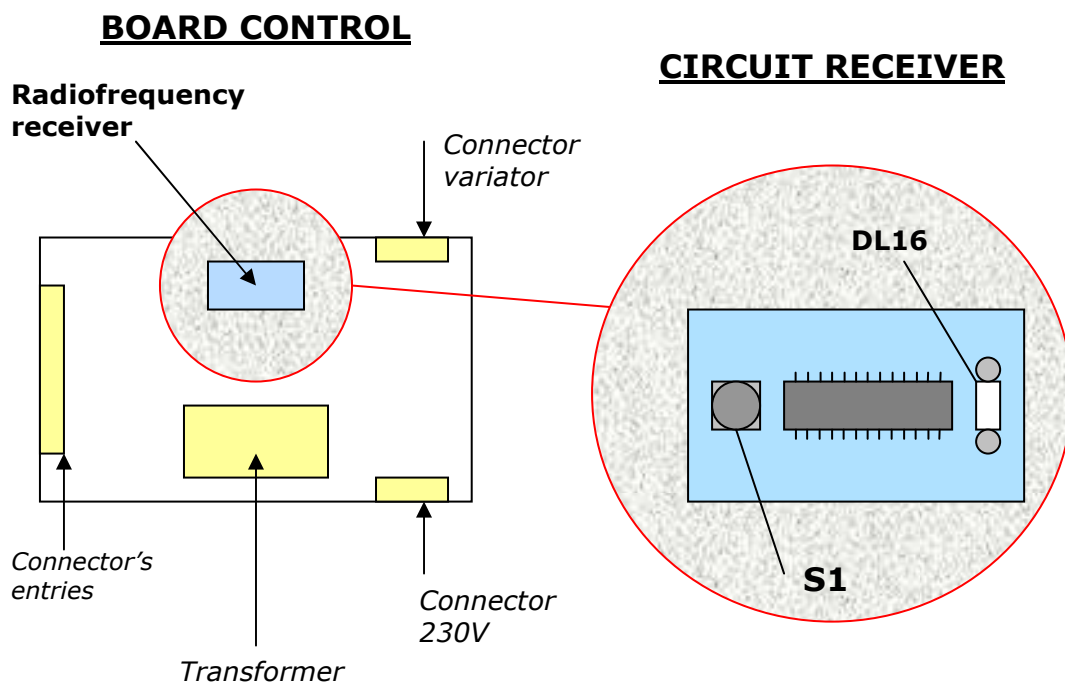

RAPID SHUTTER DOOR OF PVC

PLANT

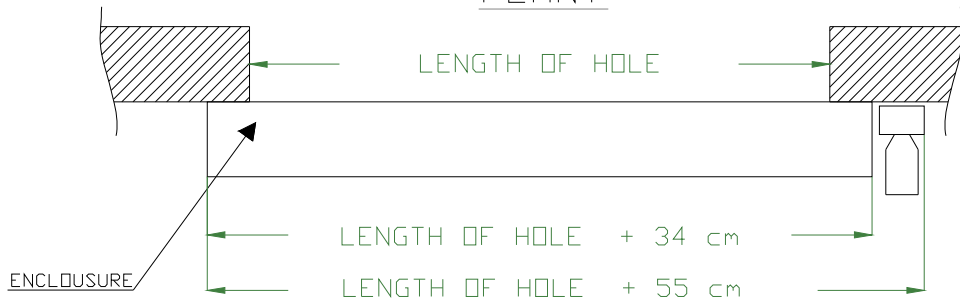

OUTRIGHT

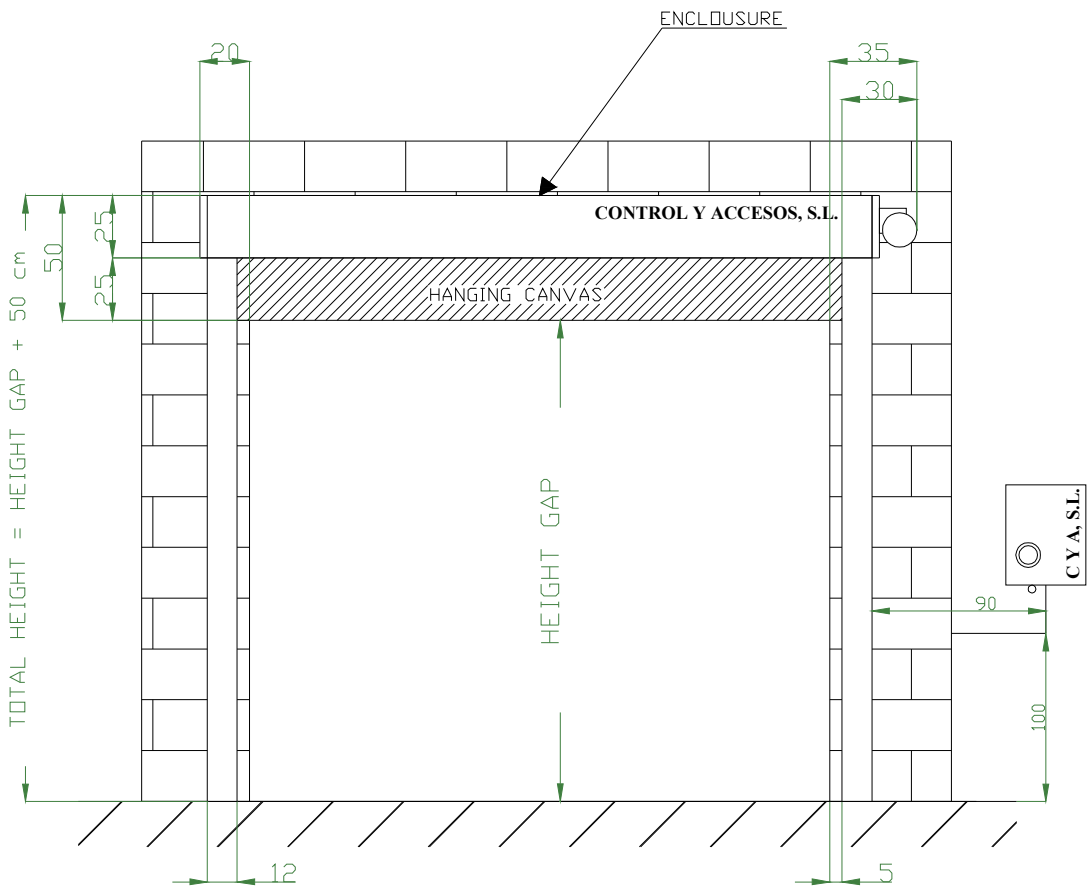

ULTRA RAPID SHUTTER DOOR WITHOUT ROOM

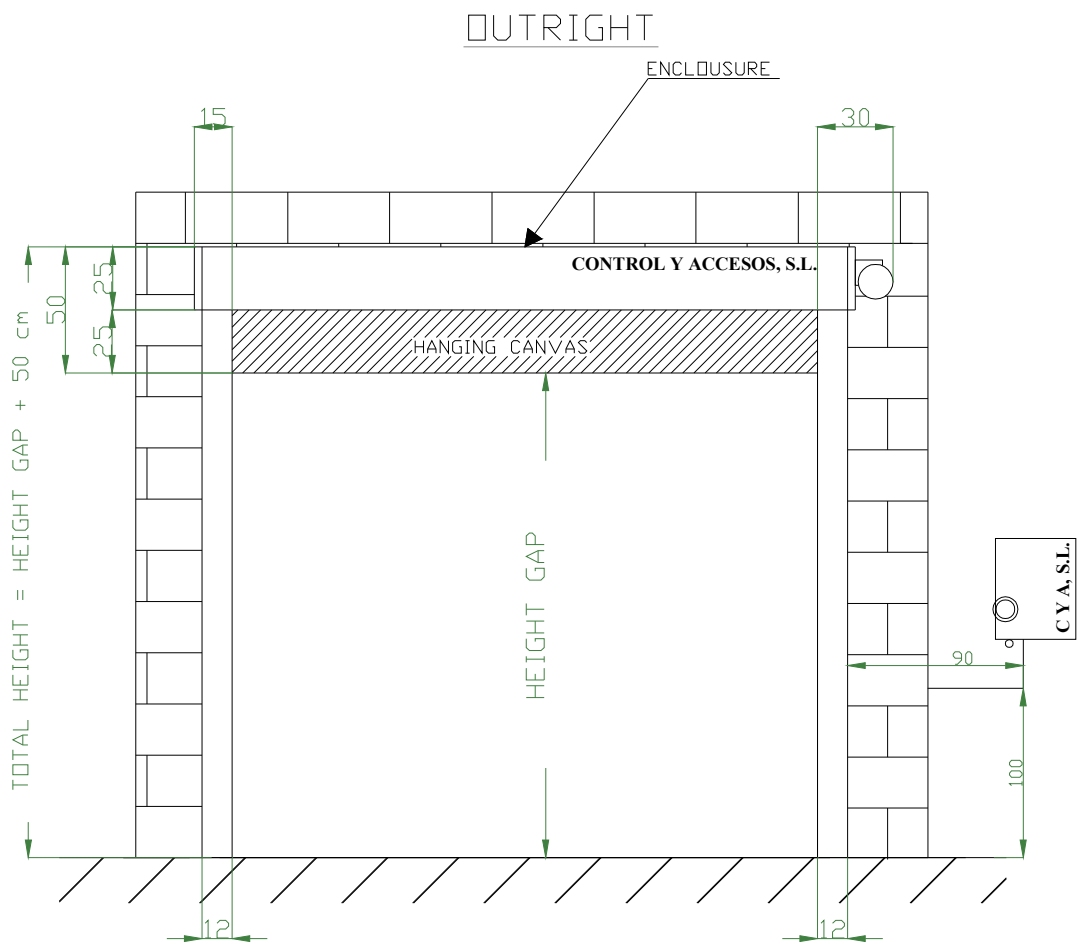
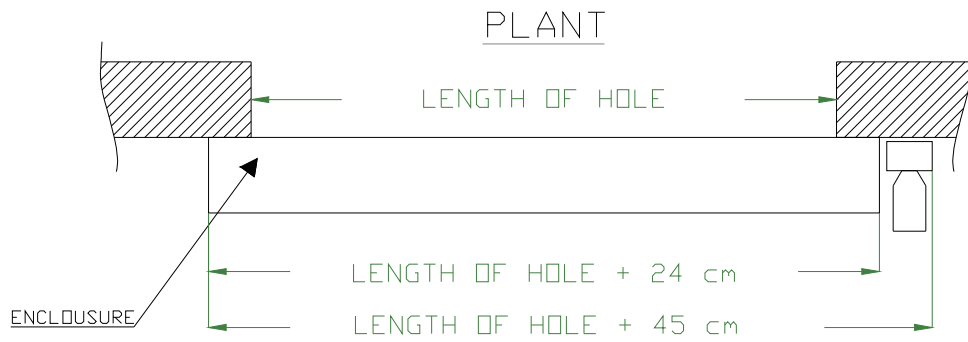

RAPID SHUTTER DOOR OF PVC REINFORCED

PLANT

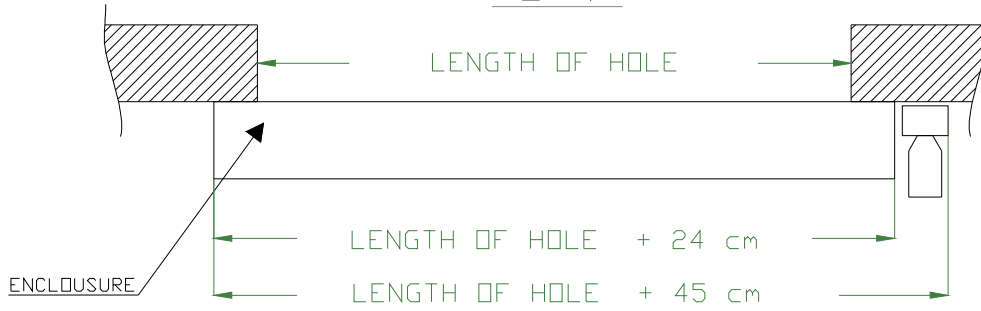

OUTRIGHT

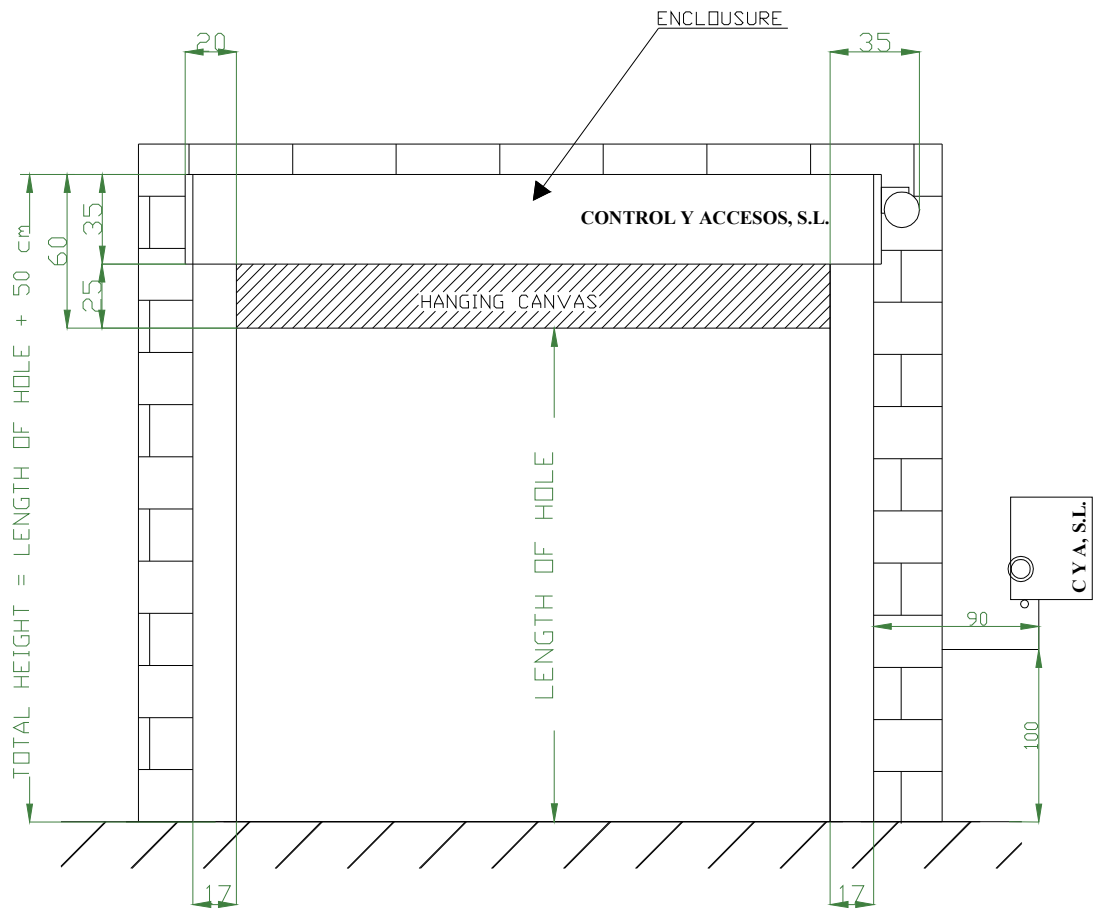

GUARANTEE CERTIFICATE

This certificate guarantees the quality of the product in the terms established by law, during a period of 2 years from the delivery date of the product. According to the law 23/2003, 1st July, for consumer goods guarantees.

It does not include the faults occasioned by negligence, beatings, usage, maintenance or improper manipulations of the same, a non-suitable voltage, with no connection to the ground installation, or wear materials due to its normal use, as well as accidents, natural disasters or any other cause beyond our control.

If any component is not working properly, it will be forwarded to the manufacturer who will analyse if it is beyond the guarantee limits. In the breakdowns of the electronic components it is necessary to present a certificate from the supplier of the electrical currency, indicating that the strain has remained within the parameters in the date when the incidence occurred.

In those incidences where the usage of the guarantee is justified, we'll opt for the repair, the replacement of the item the discount or refund of it, on the terms established by law.

The guarantee will lose its value:

- If they are modified, changed or substituted some of information of the same or of the purchase ticket.
- If the guaranteed product is manipulated or repaired without the sellers, importer or manufacturer knowledge.
- If the signature or corporate seal is not in it.

To use the guarantee, it is essential to submit this certificate of guarantee together with the purchase ticket.

GUARANTEE CERTIFICATE	
Name of Client:	
Address:	
Population:	Zip:
County:	
Country:	
Phone:	Fax:
E-mail:	
Model:	
Date of purchase:	Stamp Distributor:
	<div style="border: 1px solid black; width: 150px; height: 100px; margin: 0 auto;"></div>